



Triumphant Times

Monthly Newsletter for April 2026

<https://greencountrytriumphs.com/>

7-26
PAID
MEMB
ERS

- 1.
- 2.
- 3.
- 4.
- 5.
- 6.
- 7.
- 8.
- 9.
- 10.
- 11.
- 12.
- 13.
- 14.
- 15.
- 16.
- 17.
- 18.
- 19.
- 20.
- 21.
- 22.
- 23.
- 24.
- 25.
- 26.
- 27.
- 28.
- 29.
- 30.
- 31.
- 32.
- 33.
- 34.
- 35.
- 36.
- 37.
- 38.
- 39.
- 40.
- 41.
- 42.
- 43.
- 44.
- 45.

Club Dues Are Due June 30th or before of each year to the club Treasurer. Send \$20 to: Green Country Triumphs, C/O Jan Phillips, 5865 E 480 RD., Claremore, OK 74019

**Next Club Meeting
Tuesday April 21st
Dinner at 6:00PM
Meeting at 7:00 PM
Location: The Brook
3401 S Peoria Ave,
Tulsa, OK 74105**

Officers and Committees

Art Graves – President, Car Shows, VTR Liaison, Club Contact

Michael Burns– Vice President

Jim Murray - Member at Large

Jan/John Phillips – Treasurer

Rolf Blom – Secretary

Jon Wood – Web Master

John Phillips – Newsletter, Parts, Repairs, Appraisals, Membership
topaztr6@gmail.com

President's Address by Art Graves

Last month I told of an overnight trip to a car show. I had already done that for several regional VTR conventions. But the Kansas City adventure encouraged me to do more. Initially our son Brian went with me. And we attended national VTR conventions in Fort Worth, Texas and in Hudson, Wisconsin. The Hudson, Wisconsin convention turned out to be the springboard to the Roadster Factory Summer Party.



In 1999 the national VTR convention was held in Portland, Maine. We began making plans to attend early in the year, but a problem came up in the summer. Brian was to begin his freshman year in high school. And he wanted to play in the school band. And band practice began in August with mandatory attendance. No exceptions and no excuses. With those conditions, I figured the trip was off.

Then out of the blue, Karen told me that if I wanted to go, I should go anyway. So, I did. My Hill Country Triumph Club friend Mike McPhail and I each drove our TR6s. A bonus for this trip was that the Roadster Factory Summer Party would be held the weekend after the national VTR convention. Since we would be in the area, we would be able to do both.

The national VTR convention was great, but summer party was amazing. Summer Party was held not only on TRF grounds, but the whole area around Indiana, Pennsylvania. It was a three-day event that included drag racing, drive-in movie, vendors, car show, mountain tours, gimmick rallies – I could go on and on. That was in 1999. We went back to Summer Party every year after until Charles Runyan passed away in 2018.

Our Fourth Decade of Fun, Sun, Leaks, Fumes, Sparks, Whines & Friends

Needless to say – but I'll say it anyway – driving around the country to various car shows has become a habit. I have been to interesting places that I never would have seen otherwise. I've met a lot of British Car enthusiasts, some of whom have become close friends. More next month.

The Regional VTR Convention is April 20-24 and so I'll miss the April club meeting. Vice-president Mike Burns will conduct the meeting. Last month we discussed a few out and back trips we could take as club. With moderate April and May weather, now is a perfect time of year to go for a ride in your Triumph.



Vice President's Article by Michael Burns



Minutes of the Last Meeting for Rolf Blomm / Jim Murray by Sharon Parker

Green Country Triumph
March meeting

In attendance were 11 members with 2 driving their Triumph. John P. and Art.

New business:

Welcome our newest member, Jeff Drouin. Clark Fraiser was in attendance with Retha Browning.

Minutes:

A motion was made to accept the minutes as recorded in February newsletter. The motion passed.

Treasury report:



The donation check was mailed to McPherson College in memory of Denny Robinson. Club member, Joe Landers, matched our dollar amount. Thank you, Joe. John reported the amount we have bank funds.

Membership:

Club dues are coming in and are due before June 30th.

Car Show:

The show season is starting, and Art will be attending the British Motoring Festival in Covington, Louisiana, March 28. Covington is just outside of New Orleans.

South central VTR Regional will be in Marble Falls, TX April 20-23.

Steve suggested the we attend the 2nd annual Jenks Riverwalk car show April 18. Steve mentioned going as a club activity.

Clark discussed having a joint car show with the Jaguar and MG clubs.

Parts:

John ordered parts for his SKY. A Tr6 is for sale in south Tulsa John said the owner mentioned it needs a clutch and a slave cylinder. Steve's car is still with John Gauldin. Jim Lindsey worked a little on his TR4. Clark said his Jaguar 140 is running.

Art is having intermittent speedometer problems and has narrowed it down to 2-weak points. One being the EGR counter or the cable. Art said the EGR was in '75 and '76 Tr6. A good discussion about possible ways to bypass the EGR since it is mounted in the cable.

Activities:

The St Patrick's day party was a success. Jan said Thank You and she enjoyed everyone's company, she like the apron. The apron was embroidered with the club logo. Art and Karen found a place here in town called NAME it Embroidery. The shop has our logo artwork on file and can embroider almost anything.

May 16th or 17th a trip is planned to The Coleman Theatre in Miami, Ok.

Tulsa Capital Cruise, on route 66, the registration is still open until the end of May.

Old Business:

Mike says the Facebook page is up and running. The page is private and joining it is very easy. Mike and his wife are moderators.

Our Fourth Decade of Fun, Sun, Leaks, Fumes, Sparks, Whines & Friends

The old website with .org domain is now defunct.

John P, John O and Andy went out to Kays to check on Denny's spitfire. The car is in very good shape. Andy suggested the website Bring a Trailer for the most exposure to advertise for sale. He recommended good professional photographs, and more is better.

A motion was made and passed to adjourn the meeting.

4/5/2026 - I sold the project car, didn't get much but paid a little & they loaded it up & happily hauled it away. Kay



Steve passed the information that some damage occurred to his TR6. There is paint damage on the driver's side rear wing over the wheel opening. We will follow the repair as information is available.



Figure 1 Another show, another trophy for Paula Brown

Our Fourth Decade of Fun, Sun, Leaks, Fumes, Sparks, Whines & Friends

To Membership, etc.: by Editor John Phillips

A couple of days ago club members joined Jan and I at the annual St. Patrick's Day celebration. At least it has been annual until now. Jan is turning loose of running this activity as it is just getting to be a little too much for her to handle.



There were a couple of gifts for Jan to say thanks for the memories of about 33 years of saying come on in and make yourself at home if you can tolerate the dogs. Art presented her with an apron that is pink with a large club logo on the front which was very much appreciated. It will go well with the black apron given to me by Donna Thompson several years ago. There were some other gifts as well that she treasures.

We have had many good friends from the club over the past three decades. Sam was the first since he started the club in the first place, but there were many more. If I tried to name them all someone would get left out and may feel slighted, so I won't even try, you know who you are. Of course, some friends won't get the newsletter since they are no longer on the distribution list for multiple reasons.

Thank you all for giving us some wonderful memories to carry with us the rest of the way. Ok, speed up, or get over. We have miles to go.



Figure 2 Maybe my best idea. The rain cap is tucked under the bonnet and the boot and held at the door handles. To remove it you first open the locked boot, then the locked doors, and last bonnet. Kept my car dry inside and protected.





March 20, 2026

Green Country Triumphs
John Phillips, Membership Chairman
5865 480 Rd
Claremore, OK 74017

Dear John:

At a time when you were remembering someone special, you also thought of McPherson College and the students we serve. Thank you for your recent gift of \$2,000.00 in memory of Dennis Robinson to support the McPherson College Automotive Restoration Department. The program relies on the support from persons such as you to help provide students with scholarships, equipment and experiences that will aid them on their path to becoming the next generation of artisans.

Our liberal arts degree supports craftsmanship, critical-thinking and an entrepreneurial spirit, making our students competitive in the marketplace. This quality education contributes to well-rounded graduates who serve the restoration industry in many capacities - as restoration technicians, historians, or in a variety of roles within the car community.

Your gift in memory of Dennis Robinson ensures that our students have access to the resources they need to be successful. Please contact me if you have any questions regarding academics, scholarships, internships or donations.

Sincerely,

Amanda Gutierrez
Vice President for Automotive Restoration

Official Tax Receipt

Date processed	Designation	Amount received	Tax deductible amount
03/13/2026	Auto Restoration Program	\$2,000.00	\$2,000.00

In accordance with IRS regulations, this letter confirms that no goods or services were provided by McPherson College, in whole or in part, in exchange for your contribution. Please retain this receipt for your tax records.

Scheduled Club Activities

WHEN	WHAT	WHO
February 10th 2026	DRIVE YOUR TRIUMPH DAY	Art/John
Friday 13, March 2026	St. Patrick's Day	Jan's Last One
Saturday May 30, 2026	Tulsa's Capital Cruise Parade down Tulsa's Route 66	?
April 20-23	<u>VTR South Central Regional Convention</u> <u>Location: Marble Falls, Texas</u>	Art

Become a VTR Member

The Vintage Triumph Register has its benefits. A national club of Triumph enthusiasts spanning the globe needs you as a member. Affiliate club membership is not automatic membership with VTR.

Some of the benefits: *The Vintage Triumph* magazine, our award-winning, bi-monthly color publication.

VTR National convention

Access to a large number of local clubs

Website with reference material and members-only sections

Record Trace Certificates TR2/TR3/TR3A/TR3B

Factory trace documents on other Triumph models no longer available

Clothing, regalia, exclusive items

Specific vehicle consultants and experts

Sign up at <https://vintagetriumphregister.org>



Our Fourth Decade of Fun, Sun, Leaks, Fumes, Sparks, Whines & Friends

ROUTE US 66 CENTENNIAL

2026 HEMMINGS GREAT RACE
SPRINGFIELD, IL TO PASADENA, CA
PRESENTED BY **COKER TIRE**

Route 66!
June 20-28, 2026

The 2026 Race Begins In Springfield, IL and Runs Along Historic Route 66 to Beautiful Pasadena, CA.

Stops and Landmarks on the Route:
Pasadena, CA; San Bernardino, CA; Twentynine Palms, CA; Laughlin, NV; Kingman, AZ; Flagstaff, AZ; Gallup, NM; Albuquerque, NM; Tucuman, NM; Amarillo, TX; Oklahoma City, OK; Claremore, OK; Injin, MO; Collinsville, IL; Springfield, IL.

Overnight Lunch Stop



Our Fourth Decade of Fun, Sun, Leaks, Fumes, Sparks, Whines & Friends

Jan's St. Patrick's Day Party: The Pink Apron Award and other gifts for club service are much appreciated by both Jan and I John.



Our Fourth Decade of Fun, Sun, Leaks, Fumes, Sparks, Whines & Friends

Apologies for the quality of the pictures. John

The apron has a nice club logo on the front that I did not capture.





2026 CAR SHOW LIST **by Art Graves**

New Orleans British Motoring Festival
Location: Covington, Louisiana
Date: March 27 – March 28, 2026
Web: <https://www.bmcno.org/2025-british-motoring-festival/>

VTR South Central Regional Convention
Location: Marble Falls, Texas
Date: April 20 – April 23, 2026
Web: <https://hillcountrytriumphclub.regfox.com/2026-south-central-vtr-regionals>

Dallas All British & European Car Day
Location: White Rock Lake Park, Dallas, Texas
Date: May 2, 2026
Web: <https://allbritishcarday.com/>

The Wedge Shop Gathering
Location: ??
Date: ??, 2026
<https://www.thewedgeshop.com>

Euro-Expo Car Show
Location: Sand Springs, Oklahoma
Date: ??, 2026
Web: <http://www.jaguarcluboftulsa.com/>

TRA National Meet
Location: Madras, Oregon
Date: June 15 – June 19, 2026
Web: <https://www.triumphregister.com/national-meet>

Greater Ozarks British Motoring Club Car Show
Location: Springfield, Missouri
Date: June 26 – June 27, 2026
Web: <https://gobmc.org/>

Kansas City All British Car Day
Location: Merriam, Kansas
Date: September 5 – September 6, 2026
Web: <http://www.heartlandallbritish.com/index.html>

Brits on the Bluff
Location: Natchez, Mississippi
Date: ??, 2026
Web: <https://www.msemc.org/events/>

6-Pack Trials
Location: Nashville, Indiana
Date: September 17 – September 19, 2026
Web: <https://www.facebook.com/groups/795712742964794/posts/818655254003876/>

Triumphest
Location: Flagstaff, Arizona
Date: September 17 – September 19, 2026
Web: <http://www.dctra.org/>

Texas All British Car Day
Location: Austin, Texas
Date: October 9 – October 11, 2026
Web: <https://www.hillcountrytriumphclub.org/txabcd/>

VTR National Convention
Location: Kerrville, Texas
Date: October 14 – October 18, 2026, 2026
Web: <https://www.mntriumphs.org/vtr2025/>

British Iron All British Car Day
Location: Agri Park, Fayetteville, Arkansas
Date: October 22 – October 24, 2026
Web: <http://www.britishironwa.org/>



Our Fourth Decade of Fun, Sun, Leaks, Fumes, Sparks, Whines & Friends

TULSA'S ROUTE 66 CAPITAL CRUISE

WORLD RECORD
Classic Car Centennial
PARADE

THE BIGGEST MOMENT ON THE MOTHER ROAD
In the Capital of Route 66®

SAVE THE DATE
MAY 30, 2026
TULSA, OK, USA

DRIVE **SPONSOR** **VOLUNTEER**

BE A PART OF HISTORY

#TULSAR66PARADE
CAPITALOFROUTE66.COM

CITY OF TULSA **Route 66** **TULSA REGIONAL TOURISM** **OKLAHOMA ROUTE 66 ASSOCIATION**

Our Fourth Decade of Fun, Sun, Leaks, Fumes, Sparks, Whines & Friends

35TH ANNUAL FESTIVAL OF WHEELS
CAR, TRUCK & BIKE SHOW
BROKEN ARROW ELKS



**SAT
AUG
15**

**FOOD & DRINK
DOOR PRIZES
FAMILY FUN**

**8AM - 2PM
\$20 ENTRY**

**PRIZES AWARDED
TO TOP VEHICLE
CATEGORIES**

Our Fourth Decade of Fun, Sun, Leaks, Fumes, Sparks, Whines & Friends



SEPT 17-19, 2026

Triumphfest provides the thrill of driving our 'TR's to a destination just like the 'old days'.

At the Triumphfest we will enjoy 'Funcours', Autocross, Funkhana, tech sessions, and an awards banquet. Plus, an opportunity to meet with our Triumph friends, what a great time!



HOSTED BY THE DESERT CENTRE REGISTER OF AMERICA
WWW.DCTRA.ORG

Celebrate the Route-66 Centennial during Triumphfest - Get your kicks on Route-66 in your Triumph!



TRIUMPHFEST 2026 EVENTS

- AUTO-CROSS
- FUNKHANA
- TECH SESSION
- HOSPITALITY PARTY
- BANQUET
- AWARDS
- RAFFLE PRIZES
- VENDORS
- RALLIES
- REGALIA
- MODEL/PHOTO CONTEST
- WALKING TOURS
- SCENIC DRIVES
- DINNER CRUISES IN YOUR TR



TRIUMPHFEST 2026

TRIUMPHFEST 2026

WHERE ARE WE STAYING?



2515 E. BUTLER AVE.
FLAGSTAFF, ARIZONA 86001

Special rates are available.
928-799-7900 mention
Triumphfest 2026.

www.flagstaff.littleamerica.com



FLAGSTAFF, ARIZONA.

Elevation 6910 ft, cool and green all year. A great place to have a Triumphfest and a great jump-off place to visit the sites of Northern Arizona.

Find more sites and activities at www.discoverflagstaff.com

Our Fourth Decade of Fun, Sun, Leaks, Fumes, Sparks, Whines & Friends

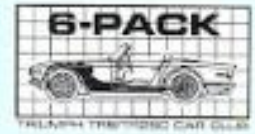

6-PACK TRials 2026

Nashville, IN
September 17 – 19, 2026

The 2026 6-PACK TRials will be in Nashville, IN! The event will be based at the Abe Martin Lodge in Brown County State Park. Entry to the Park is included in your registration. The Park and the surrounding area have excellent driving roads, vineyards, and other sites. Located between Columbus and Bloomington, IN, Nashville is an artist's colony with restaurants, distilleries, breweries, and shopping.

Event and Lodge Registration opens October 10, 2026

Abe Martin Lodge Reservations: Call **877-563-4371**

- Select Option 1 for Hotel and Cabin Reservations
- Select Option 1 for Abe Martin Lodge
- Provide Event Code **0917TR** to Reserve Rooms at Abe Martin Lodge



Event Registration Form on Facebook:
6-Pack TRials – 2026



Our Fourth Decade of Fun, Sun, Leaks, Fumes, Sparks, Whines & Friends



**Y.O. RANCH HOTEL
OCT. 14-18, 2026
KERRVILLE, TEXAS**

**Greetings from:
Deep in the Heart of Texas**

The South Texas Triumph Association is excited to be your host for the 2026 Vintage Triumph Registry National Conference.

Event Dates: October 14-18, 2026

Location: Y.O. Ranch Hotel and Conference Center, Kerrville, Texas

This years event is located DEEP IN THE HEART OF TEXAS, near the center of paradise, also known as the Texas Hill Country! This easy to access region is well known for its scenic beauty, winding roads, art galleries, shopping, dining, antiquing, award winning wineries and excellent back roads filled with friendly small towns to visit.

Please visit our website at STTA.club/VTR2026 for more information about this not to be miss event!

**Best Regards,
David Cochran, President STTA**



For More Information
or
to Register Today
www.stta.club/VTR2026

Our Fourth Decade of Fun, Sun, Leaks, Fumes, Sparks, Whines & Friends



BRITS *in the* **OZARKS**

24th ALL BRITISH CAR & CYCLE SHOW

Hosted by British Iron Touring Club of NW Arkansas

Show held in Fayetteville, AR (UofA Agri Park)

South of Exit 67-A off I-49

Thursday, October 22nd – Saturday, October 25th (rain or shine)

ALL PROCEEDS BENEFITTING



SCHEDULE OF ACTIVITIES

Thursday, Oct. 22nd

- 9AM Departure from Holiday Inn Convention Center of Northwest Arkansas (Hotel)
**Quick and leisure drives available both days*
- 10AM-9PM Torchy's Taco Rogers Restaurant Fundraiser (4950 W Pauline Whitaker Pkwy, Rogers, AR)

Friday, Oct. 23rd

- 9AM Departure from Holiday Inn Convention Center of Northwest Arkansas (Hotel)
**Quick and leisure drives available both days*
- 4 – 6PM Show Registration walks-ups welcome
**Also available on site the day of the show (Oct. 24th) starting at 8:30AM*
- Cook out and parking lot party 6:00 PM at the **Holiday Inn Convention Center of Northwest Arkansas** (we will be here until the beer runs out or we are tired)

Saturday, Oct. 24th

- 10 AM – 2PM Car and cycle display and popular choice judging at UofA Agri Park, North Garland Street, Fayetteville, Arkansas
**Day of registration starting at 8:30AM*
- Lunch and concessions available on site
- Silent Auction (donations welcomed)
- 6 PM | Awards Dinner **Holiday Inn Convention Center of Northwest Arkansas**
SPECIAL GUEST: Tim Suddard – FOUNDER AND EDITOR EMERITUS OF CLASSIC MOTORSPORTS AND GRASSROOTS MOTORSPORTS MAGAZINES

TICKETS required for Awards Dinner event. Only 200 Dinner Tickets will be **SOLD** for this exclusive event! Order your tickets **TODAY!**

Register online here:



or complete and return the attached form

*Please note: *No vendors per U of A Agri park regulations*

Our Fourth Decade of Fun, Sun, Leaks, Fumes, Sparks, Whines & Friends



Greasy Hands Garage North Update

by John Phillips

3/22/2026 -

Yesterday I decided it was time to install the new exterior mirror adjustment switch in the Saturn Sky. This is the second time this has been done but I had less trouble the first time.

The door panel had to be removed by removing two cover panels, 3 screws and pulling out the push pins holding the panel to the door. The door handle cable was released, the electrical connection modules removed for the windows, locks and mirrors.

The bar used to pull the door shut was removed then the small panel housing the window and mirror switches was free to work on separately. That was a lot easier to say than to do.

The non-working switch was removed and a new switch was reinstalled in its place. Reassembly was just working backwards to get it all back together.

A partial rework is appropriate as I found two retaining pins for the panel on the floor after the panel was back in place. Also, a strange small

plastic piece that looks like some kind of retainer was found but I have no idea where it goes.

The new switch works as it should, so I guess the job was a success but less than fulfilling. Another issue was that I was up and down so many times my legs wore out and when finished I could not stand up one last time until resting for a few minutes. I seem to lack any kind of stamina for working on cars. I have added some things to my exercises.

3/29/2026 – Today I got back to the Sky to replace the two door panel retaining push pins that fell out while replacing the outside mirror switch. No trouble with the screw at the B pillar or two retaining screws near the center of the door or the one behind the handle went in ok but one of the retaining tabs on the screw cover broke off. I am attempting to glue it back on using some leftover Kwik Set. Hope it works

Follow up, this J B Weld repair did not work.

The answer was to put a dab of silicone on the back of the cover and putting it in place to cover the screw.

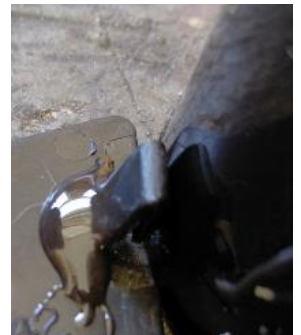

Our Fourth Decade of Fun, Sun, Leaks, Fumes, Sparks, Whines & Friends

The following work was done in 2014 during a more productive period at GHGN. Now we mostly remember some of the more significant projects. Enjoy.

Shop Creed: No job so small we can't mess it up.
Warranty: If it breaks you get to keep all the pieces.

3/11/2014 – Here we go again. Today in my quest to finish under the dash and install the remaining dash components, I found that the oil feed kit was not installed to my satisfaction, nor was the oil line to the pressure gauge. They needed to be reversed to prevent a too severe bend in the oil line to the gauge. The line received with the car was broken and I suspect that is why.

After disassembly of the noted lines the first thing re-assembled was the oil pressure line which went smoothly and fixed the problem of the too severe bend.

When I attempted to attach the TEE to the engine block at the oil pressure switch port the male threads were too large to fit in the hole. After a wasted trip to the hardware store to find a reducing fitting I decided to re-thread the male end of the TEE. Although this worked, I think the thread should have been a pipe thread type as opposed to a straight thread. At any rate everything tightened up well and hopefully it will not leak when the engine is started. In hindsight, if the TEE thread had been a tapered pipe thread in lieu of a straight thread it probably would have worked just fine.



The one thing perplexing me now is that the drive cable for the tachometer appears to be about an inch short. There were 3 others to which the first was compared and they are all the same length. Oh well, we will see what happens when the gauges go in.

Wayne has a scuttle vent flap to be installed on this car even though it did not come with one. This should be interesting. He picked up the flap to get it painted white to match the car. He got here on a great looking 3-wheel Honda Gull Wing conversion. Said he and Carol went all the way to Alaska on it one day after the conversion was finished.

Next up, figure out the assembly of the scuttle vent hardware under the dash before it gets crowded in there.

3/12/2014 – It appears that most of the pieces used to assemble the scuttle vent are not available after all so on to installing the horns.

The aftermarket horns in the car did not work so I found a set in the attic that do work and installed them. This job is best done before the bumper support brackets are installed due to the lack of room available to install the attach bolts.

It took a long time to do this apparently simple job so after they were in I was tired of wallowing around on the creeper trying to get in a position to hold the horn, hold the bolt with washers and turn the bolt enough to get it started in the holes. I called it a day.



3/13/2014 – Today started with looking for the hardware to install the radiator shroud. I had looked everywhere for it at least twice so I started all over. After going through everything again it was found on the package tray inside the car where it had been overlooked at least 5 times.

Jack Finch showed up about then to get his backup bonnet release installed. Everything about this kit is very straight forward but getting everything positioned properly is a pain in the butt. If you put one of these in your car be sure to put

Our Fourth Decade of Fun, Sun, Leaks, Fumes, Sparks, Whines & Friends

the grommet in the ¼" hole before you insert the pull shaft.

The real problem comes when aligning the lever/bolt/bushing/washer and attaching all of this to the side of the bonnet hold down bracket. The bushing wants to ride on the washer which binds up the whole assembly and getting everything to stay in place while tightening the bolt into the nyloc nut is very difficult. We eventually prevailed and Jack was on his way.

Next my attention went to installing the small gauges in the wood dash fascia prior to offering up the wood fascia to the metal fascia. Offering up is one of the terms used by the Brits in the manuals.

There was enough hardware to take care of the small gauges but I will have to find some for the large gauges. Two of the retainers are missing as are 3 of the retaining nuts.



With the wood fascia ready to install it was time to make sure the wiring harness was ready to hook up. As it turned out 3 of the bulb holders had been removed from the harness so 3 spares were cut from an old wiring harness and spliced on Wayne's harness. Insulation had been damaged in 5 places so that was taped up to insulate the wires.

Also there were no bulbs in the harness so all but one bulb was found and used from the shop



stash. If Wayne has some in all the stuff here they will be shuffled into the shop stash. Enough for today.

3/17/2014 – I went to the shop later than normal to see if I could get the wood dash and gauges all installed and sorted out. That went pretty well until Paul showed up wanting a haircut. The work kind of stopped after that.

One thing that will require some work is connecting the tach drive cable to the tachometer. Either the engine is sitting too far forward or the clocking of the distributor is not correct. The cable is just too short.

I tried two different routings and neither of them will allow for connection. It may be time to move the distributor one tooth.

There are still a few loose wires to connect under the small gauges but for the most part the dash is getting very close to being finished.

The duct work is yet to be installed, some parts are still needed for the scuttle vent operation,



and a brace is yet to be installed on the passenger side. Getting there, then the interior and it is close to done.

3/24/2014 – The accelerator shaft bushing kits ordered from Art Lipp arrived today but installation will have to wait until the eye heals up some more. A few more days and I can get back to work.

3/25/2014 – I ventured back into the shop for a little while today. I was tempted to see how the new throttle shaft bushings were going to work out. The bushings made by Art Lipp are exactly what I have been trying to find or have made since

Engine Noise

Snippets from e-mail, etc. worth sharing.
John,

I read about your adventures with TR6 accelerator shaft bushings (hereafter referred to as ASB) in the last issue of your newsletter with great interest as most all of us have had plenty of cursing exercise when trying to install those pesky ASB.

A while back I saw a set of ASB demonstrated at a VTR event in Flagstaff that has solved that cursing situation for me. A guy by the name of Art Lipp has developed some ASB that are in two pieces and are much easier to install (still no 5 minute job) and mostly eliminate much of that loud verbal exercise. The ASB are available from Art Lipp (lipp04@yahoo.com) for \$20.00 + \$5.00 S&H.

Well worth it!

John Gauldin
Triumphworld Services, Inc
405-250-0903

Editor: I bought two sets, one for Wayne and one for me.
John P.



a couple of years before I retired. The concept is not new to me but Art does his own machining and I could never locate a machining source.

With a little grinding using a dremel tool the holes in the firewall were enlarged just a little to provide for a press fit of the Delrin bushings. The passenger side bushing was pressed in from the engine side of the firewall first.

The shaft then goes through the hole first, then the bushing and retainer are placed on the shaft. The left bushing is then pushed into the hole.

At this point the assembly is ready for the throttle shaft lever. Ok, where is that darned lever? After performing yet another search through the dwindling pile of parts no lever was found. Ditto the search of the club stash in the attic. Drat!!

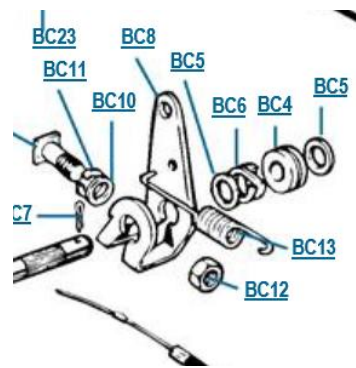

At this point I notified Wayne to order more parts. Gotta have a lever. The spring is here, spring washer is here but no lever or pinch bolt and nut.

As the part is no longer available I sent out a message to everybody on the mailing list to see if anyone has a lever available. Hopefully one will show up.

The bushings worked just as I had imagined they would. If resources had been available I would have been using them for some time. Here is the drawing I made quite a while back.

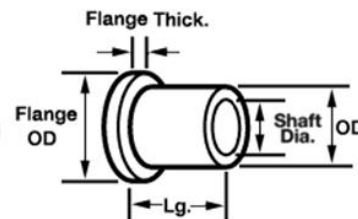

**Material – Delrin,
Nylon, Teflon, Etc.**
OD: .650"
Shaft Dia.: .375"
Length: .425" optional
Flange Thickness: .100"
optional
Flange OD .900"
optional

Comparing my information to the picture of the actual kit it is obvious that the concepts are quite similar. I guess I will have to be content with knowing my idea works and that I can actually buy the parts for \$20 plus \$5 shipping.

I think my idea for retaining the bushing on the driver side is better than the retaining ring seen in the picture but this is a fine alternative. The kit is installed and I am waiting for a lever to complete the installation of the accelerator shaft.

JOHN'S QUICK TIPS

Plug Lead Positions (Fig. 55)

Ensure that the plug leads are attached to the sparking plugs as shown. Firing order is 1, 5, 3, 6, 2, 4, taken in anti-clockwise order, as viewed from the top of the rotor arm.

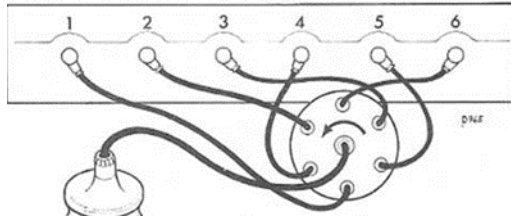

TR6 Soft Top Folding

To prevent window damage when top is down fold TR6 top as shown.



Unsnap the top from the rear bow and beneath each side window. Spread over boot lid.



2. Fold top forward without folding back window



3. Fold side windows on top without folding side windows, tuck top down behind seats, add cover.

https://www.youtube.com/watch?v=IS2FhnWK6_o&feature=youtu.be

Products Appropriate for Your Car

Not the only option but good ones.

Standard TR6 Tire Size: 215 X 65 X 15

This web site is terrific for selecting a tire size that will work with your speedometer.

<https://www.tacomaworld.com/tirecalc?tires=215-65r15-205-70r15>

Classic Car Motor Oil
PennGrade 1, 20W-50



<http://www.classiccarmotoroil.com/>

Spin on oil filter sizes: TR6 Wix 51516. TR8 WIX 51515

*Coolant: Option 1; Evans Waterless High-Performance Coolant is specially formulated for gasoline engines in classic cars and high-performance vehicles. <http://www.evanscooling.com/>
Coolant: Option 2; Peak anti-freeze, no water.

Transmission: 40 Wt. Non-detergent Motor Oil or
Gear Oil: GL4 grade which is lower in sulphur. GL5 not recommended.



For TR8

Differential: Red Line Heavy Shockproof Gear Oil



Brake Fluid: Valvoline Synthetic DOT4/5

Spline Lubricant – CV Joint Grease

Star Tron Fuel Additive: For use with ethanol fuel if you have to use it.



Lubrication for front trunnions on TR6

Our Fourth Decade of Fun, Sun, Leaks, Fumes, Sparks, Whines & Friends



What's on the [Web Site](#)

Seat Belt Refurbish
Service After Storage
Rear Wheel Bearing End Float
Speaker Box Install
TR6 Wind wings
Rear Sway Bar Installation
Triumph Rain Cover
Flywheel Ring gear rework
Rebuilding Triumph TR Trans/Overdrive
Rebuilding Stromberg Carburetors
TR6 Wiring Diagrams

How does one know the alternator belt is tight enough? If you can turn the fan/pulley with your hand, it is not tight enough. If you can twist the belt 90° or more, your belt is not tight enough.

What is your car worth? Hagerty Valuation Tool

<https://www.hagerty.com/valuationtools>

GCT Merchandise

SEE NEXT TO LAST PAGE

LESSONS LEARNED

When using an electronic ignition system bypass of the ballast resistor is highly recommended. This resistor is for protection of ignition points (which are no longer part of the system) and lowers voltage to the plugs. All 12 V are needed. Exception: Leave Tach wiring if applicable.

When diff seals leak, clean the vent.

Cleaning the vent releases pressure in the diff and many times stops leaks.

Coolant hoses get loose over time. Be sure to tighten them periodically.

The rear hubs on IRS cars are known to shear causing the wheel to separate from car while moving. Check by moving the raised wheel in the caster/camber attitude to check for play. There should be none.

Thrust bearing end float should be .011" max. Push the crank shaft (fan) rearward as far as it will go. The crank should move forward when the clutch is depressed. It should move between .004" (0.1016 mm) and .011" (0.2794 mm).

Find paint codes at : [Paint Ref.com](http://PaintRef.com) or <https://www.automotivetouchup.com/>

Early TR6 Seat Backs Won't Stay On
Cause: Straps in seat back are stretched.
Repair: Remove cover and shorten the straps to tight. Not too hard.

Gasket Sealant Aviation Grade

So far found only at NAPA and considered best for gasket sealing. Does not harden.



<https://www.facebook.com/search/top/?q=Urban%20Auto%20Tulsa>
Alignments for Triumphs!!!!

Our Fourth Decade of Fun, Sun, Leaks, Fumes, Sparks, Whines & Friends



Bits of Triumph

Wynnell Gorman
wynnell@bitsoftriumph.com



To explore website:
Scan here

*Embroidery Inspired by
Triumphs & their Drivers*

<https://bitsoftriumph.com>
Mobile: 469-383-2009
4610 Jakes Way, Midlothian, TX 76065

LiteZupp Industries, LLC

LED lighting for your Classic British Auto



Exterior LEDs
Dash LEDs
LED Headlamps
Flashers
LED kits

sales@litezupp.com
www.litezupp.com
www.facebook.com/litezupp

We can see you now!



TRIUMPHWORLD SERVICES, Inc.

Specializing in restoration, repair and
parts for the English sportscar

TRIUMPH

John R. Gauldin
Edmond, Oklahoma

(405) 250-0903
trdr@cox.net

GCT Merchandise

Visit the **Cafe Press** store to
shop for Green Country
Triumphs apparel and
merchandise

<https://www.cafepress.com/greencountrytriumphs>

Classified Section

Andy Wilmes
Retired Owner
Admiral Alignment
+1 (918) 232-3273 Mobile
awilmes@atlasok.com
13503 N 155th East Ave.
Collinsville, OK 74021



Assorted TR3 & TR4 parts
Contact: Larry*
cartravel@pobox.com

Land's End Merchandise & Club Logo

Inbox



Art Graves

to me, Rob, Dennis

Hi John, Rob & Denny,

Please review my message below and set up your own accounts with Land's End. If all looks good, John, please distribute to the club.

Thanks,
Art

Green Country Triumph Club Members,
As a result of some discussion at the June business meeting, I have taken steps to make available shirts and hats with our club logo using Land's End as the retailer. Actually, you can get almost anything embroidered with our club logo from Land's End. (Even pajamas, as I half-jokingly stated at the meeting.)

Each member can order as many items as desired; we do not have to make a bulk order.

To do this, log in to Land's End using this link: <https://business.landsend.com/> . In the top right corner click on the "MY ACCOUNT" icon to create or sign in in to your account. You must have an account to order merchandise. Once you have an account, click on your "name" icon, located in the same place as the "MY ACCOUNT" icon, and select 'My Logos'. Then click on "ASSOCIATE A LOGO TO MY ACCOUNT". Enter Logo Reference Number "1617508" and Customer Number "4853648" and click "ADD TO LIBRARY".

Now that you have an account and the club's logo associated to it, 'Commence to shopping', as Jed Clampett would say. The charge to add the logo to any garment is \$6.95, so a \$50.00 pajama bottom with our logo will cost you \$56.95.

The logo size is 3.5" X 3.22". The colors of the stitching may be changed at any time for any color fabric. For example, if the fabric were black, the Oklahoma outline could be made white. This example shows the logo on a light blue garment.

I believe Land's End products are of high quality and are priced accordingly. However they are forever having sales, promotions offering to add a logo at no charge and free shipping.

Cheers,



Our Fourth Decade of Fun, Sun, Leaks, Fumes, Sparks, Whines & Friends

Greasy Hands Garage North Has Used **FREE TR6
Parts If You Need Something
Structural parts for suspension and steering
Transmissions and a Differential
Windscreen Frames, Some with Glass
Lots of other stuff so if you need something for your
TR6 contact:**

**John Phillips at topaztr6@gmail.com or phone (918
527-2629**



2008 Saturn Sky Redline (Turbo), \$10,000
Excellent condition. John Phillips
topaztr6@gmail.com (918) 527-2629



Complete cars shown are also available for purchase.



1979 Spitfire



Our Fourth Decade of Fun, Sun, Leaks, Fumes, Sparks, Whines & Friends

1933 Chevy Roadster – Perfect restoration



Our Fourth Decade of Fun, Sun, Leaks, Fumes, Sparks, Whines & Friends

1934 Ford Coupe: 350 Chevy engine. Runs great. Denny's favorite driver.



Our Fourth Decade of Fun, Sun, Leaks, Fumes, Sparks, Whines & Friends



Our Fourth Decade of Fun, Sun, Leaks, Fumes, Sparks, Whines & Friends



Car trailer is also available. [Has](#) frame for vinyl cover, ramps and a [winch](#).



Our Fourth Decade of Fun, Sun, Leaks, Fumes, Sparks, Whines & Friends

IF INTERESTED IN THE RED/ORANGE CARS
OR TRAILER ABOVE CONTACT
KAY ROBINSON
(918) 346-0306 OR robinson_kay@sbcglobal.net

DENNY'S PARTS FOR SALE

Triumph TR3A Parts for Sale

One TR3 wire wheel 15"
Battery Box
TR3 Transmission
New in box tire storage lid, red
New Muffler, still wrapped in plastic
Stainless Brake Tubes and fittings
Chrome Guard and Brackets for exhaust

1962 Triumph TR3 parts available:

Several drive shafts
2 frames, 1 with small hubcaps
Several fuel tanks
Several rear ends
Several small engine body parts
For more information contact Dennis Robinson @ 918-346-0900.

deugenerobinson@icloud.com





GREEN COUNRY TRIUMPH CLUB MEMBERSHIP APPLICATION & RENEWAL

Please complete information for each member in the household. Membership \$20 Dues = maximum TWO voting members in family. Common information needs to be listed only one time for family members.

Membership benefits typically include reduced cost on parts, tech support, access to required tools and repair facilities, extra hands to accomplish labor and a full activities calendar to enjoy club fellowship.

PEOPLE STUFF	MEMBER INFO	
MEMBER NAME		
MEMBER NAME		
MAILING ADDRESS		
PHONE NUMBER		
E-MAIL ADDRESS		
V.T.R MEMBER?	YES	NO
6-PACK Member?	YES	NO
TRA MEMBER?	YES	NO
OTHER CLUB?		

CAR MODEL	YEAR	COMMISSION#

SEND YOUR DUES TO THE CLUB TREASURER: \$20

Make Checks Payable <u>To</u> GREEN COUNTRY TRIUMPHS
Check # Check Date

GCT C/O JAN or JOHN PHILLIPS
 5865 E. 480 RD
 CLAREMORE, OK 74017
 (918) 341-8903
 tr6@atlasok.com

Dues are payable on July 1st each year. If you join(ed) between Jan. 1st and Jul. 1st, next dues are payable July 1st in the year following the year in which you join(ed). Membership is discontinued Oct. 1st following the date dues were due.